

# Flange Units

UCF 200 4 Hole Flange Units

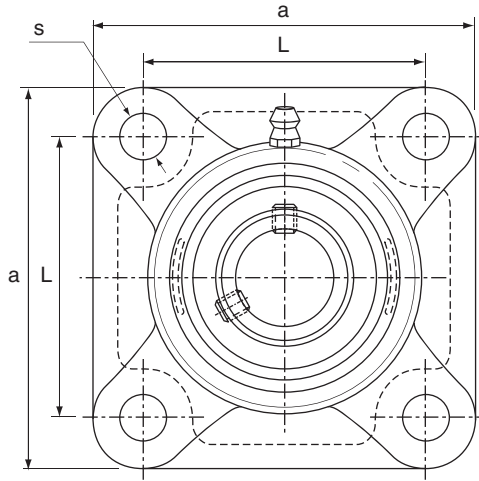
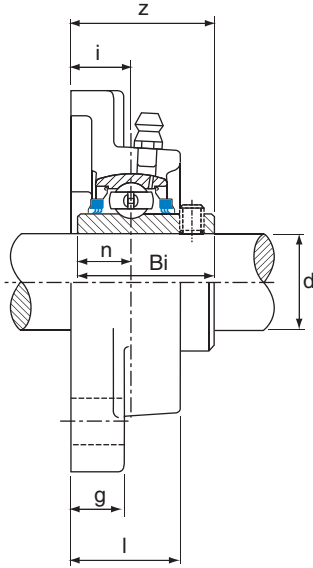

## UCF 200 4 Hole Flange Units (Normal Duty)

Bearing Unit	Shaft Dia.		a	L	i	g	l	s	z	Bi	n	Bolt Size		Insert No.	Housing No.	Weight kg
	d inch	d mm										inch	mm			
UCF 204	3/4"	20	86	64	15	12	25.5	12	33.3	31.0	12.7	3/8"	M10	UC 204	F 204	0.6
UCF 204-12		20	86	64	15	12	25.5	12	33.3	31.0	12.7		M10	UC 204-12		
UCF 205	1"	25	95	70	16	14	27	12	35.8	34.1	14.3	3/8"	M10	UC 205	F 205	0.8
UCF 205-16		25	95	70	16	14	27	12	35.8	34.1	14.3		M10	UC 205-16		
UCF 206	1.1/8"	30	108	83	18	14	31	12	40.2	38.1	15.9	3/8"	M10	UC 206	F 206	1.1
UCF 206-18		30	108	83	18	14	31	12	40.2	38.1	15.9		M10	UC 206-18		
UCF 207	1.1/4"	35	117	92	19	16	34	14	44.4	42.9	17.5	7/16"	M12	UC 207	F 207	1.5
UCF 207-20		35	117	92	19	16	34	14	44.4	42.9	17.5		M12	UC 207-20		
UCF 207-22		1.3/8"	35	117	92	19	16	34	14	44.4	42.9		17.5	M12		
UCF 208	1.1/2"	40	130	102	21	16	36	16	51.2	49.2	19.0	1/2"	M14	UC 208	F 208	1.9
UCF 208-24		40	130	102	21	16	36	16	51.2	49.2	19.0		M14	UC 208-24		
UCF 209	1.3/4"	45	137	105	22	18	38	16	52.2	49.2	19.0	1/2"	M14	UC 209	F 209	2.3
UCF 209-28		45	137	105	22	18	38	16	52.2	49.2	19.0		M14	UC 209-28		
UCF 210	2"	50	143	111	22	18	40	16	54.6	51.6	19.0	1/2"	M14	UC 210	F 210	2.5
UCF 210-32		50	143	111	22	18	40	16	54.6	51.6	19.0		M14	UC 210-32		
UCF 211	2"	55	162	130	25	20	43	19	58.4	55.6	22.2	5/8"	M16	UC 211	F 211	3.4
UCF 211-32		55	162	130	25	20	43	19	58.4	55.6	22.2		M16	UC 211-32		
UCF 212	2.1/4"	60	175	143	29	20	48	19	68.7	65.1	25.4	5/8"	M16	UC 212	F 212	4.4
UCF 212-36		60	175	143	29	20	48	19	68.7	65.1	25.4		M16	UC 212-36		
UCF 213	2.1/2"	65	187	149	30	22	50	19	69.7	65.1	25.4	5/8"	M16	UC 213	F 213	5.3
UCF 213-40		65	187	149	30	22	50	19	69.7	65.1	25.4		M16	UC 213-40		
UCF 214	2.3/4"	70	193	152	31	22	54	19	75.4	74.6	30.2	5/8"	M16	UC 214	F 214	6.0
UCF 214-44		70	193	152	31	22	54	19	75.4	74.6	30.2		M16	UC 214-44		
UCF 215	3"	75	200	159	34	22	56	19	78.5	77.8	33.3	5/8"	M16	UC 215	F 215	6.6
UCF 215-48		75	200	159	34	22	56	19	78.5	77.8	33.3		M16	UC 215-48		
UCF 216		80	208	165	34	22	58	23	83.3	82.6	33.3		M20	UC 216	F 216	7.5

All dimensions in millimetres unless otherwise stated. Every effort has been taken to ensure that the data listed in this catalogue is correct. Challenge accepts no liability for any inaccuracies or damage caused.